

www.drakecorp.com



- extra strong
- extra light weight
- extra UV resistant
- interlocking
- easy handling
- easy maintenance

High Back Folding Chair

FAN CHAIR



Made in USA

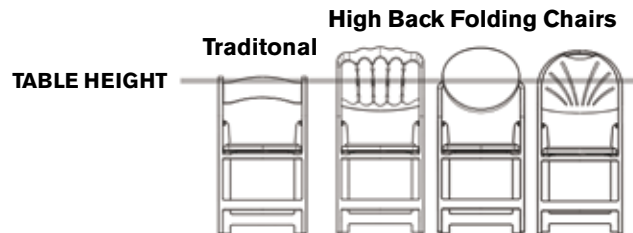

Our HIGH BACK CHAIRS towering the tables with their classical rich lines, will stand out and look fabulous in any setting, complementing your table top designs whether used with additional decorations or simply bare.

In Europe:



tel +39 02 43 79 46
email info@centroerre.com

Drake Corp.

154 Tices Lane
East Brunswick, NJ 08816, USA
tel +1 732 254 1530
fax +1 732 254 3509
email contactUS@drakecorp.com

FAN FOLDING & STACKING CHAIRS

No more hanging on racks as with similar chairs. Our chairs fold, stack (horizontally and vertically), and come equipped with an interlocking feature that makes moving and storing them quite simple. They are strong, durable, weatherproof, UV protected, don't need painting and require very little maintenance. Fan are well known folding and stacking chairs by Drake. The back is very flexible to meet higher comfort standards and to make the entire chair more impact resistant at the same time. The backs have furthermore been designed to have a smooth surface that's not textured, which makes it much easier to clean.

EXTRA STRONG & LONG LASTING

FAN chairs are made of a dual density technopolymer. The result is another incredible, exceptionally strong, and good looking chair for the Special Event Market.



SMART DESIGN

The LOAD rests on the two bars supporting the seat, NOT on the screws as on similar chairs. All of our folding chairs must comply with a 500lb. of static vertical weight standard. FEDERAL SPECIFICATION AA-C-291F

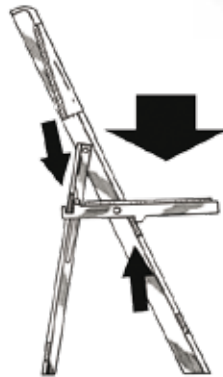

Chair dimensions when folded:
 17 3/8" x 41 1/4" x 2 1/4" [inches]
 44 x 105 x 6 [cm]

STACK heights [inches] [cm]
 Stack of 25: 59"h 148 h
 Stack of 30: 70"h 178 h
 Stack of 32: 75"h 190 h
 Stack of 50: 117"h 298 h

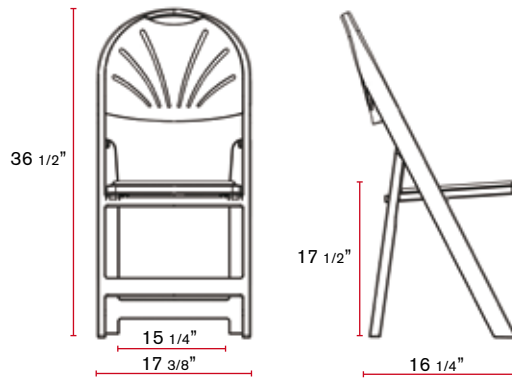

PACKAGING

Shipped in a box of 5.
 Box Weight: [52 lb.] [23.5kg]
 Box Dim.: 17 3/4" x 41 1/2" x 12" [inches]
 45 x 106 x 33 [cm]

- item# **5FanW-W** Fan White
- item# **5FanB-B** Fan Black

* custom colors available subject to minimum quantities.



FAN CHAIR ACCESSORIES

Chair link and spacer

- Snap on, NO TOOLS required
- Leaves 3" between linked chairs
- Stacks for storage

Engraved 3 3/4" x 1 1/2" Drake Logo could be replaced with your logo for a one time set up fee. Placeholder can be used with business card, advertising card, reserved seating card, row and seat number card, event card.
 Item# **3LSWP** - white connector
 Item# **3LSBP** - black connector

Pallets

Thermoformed HDPE pallet with a capacity of 350 lb. of distributed load • Item# **3Base-2200**

Stack Covers

Breathable non-woven polyester material. A 52" lateral slit with Velcro eases up positioning of the cover on the stack and a Velcro buckle adds extra security. Bottom edge is hemmed for durability. Dim. 18" x 42" x 58" h
 Item# **3ST25TNT-R**

Chair truck

Strong sturdy, making handling and moving chairs easy. 4 pneumatic wheels 10" closed cell foam tires, ball bearing hubs, powder coated steel frame. Expanded metal backguard & 54" aluminum fenders to protect load from rubbing on tires. 34" long forks, 7/8" diameter, 14 3/4" apart, designed for heavy duty hauling. MAX LOAD: 750 lbs. Weight: 97 lbs.
 Item# **3TRCKDR**

